



Designers and Manufacturers of Hydraulic and Pneumatic Equipment

SC HYDRAULIC ENGINEERING CORPORATION

1130 Columbia Street - Brea, California 92821 - USA • Phone (714) 257-4800 - Fax (714) 257-4810

FLOW CONTROL & AIR PILOT SWITCH VALVES

V
A
L
V
E



A "High Pressure" History...

An innovator and pioneer in the field of hydraulic engineering, SC Hydraulic has been manufacturing air-driven liquid pumps for more than a half of a century.

Founded in 1953 by Bob Vedder and Willie Mohler, the company started with only a few core products. Basically air-driven liquid pumps. Today, SC Hydraulic's product line has expanded to include an extensive collection of air and gas boosters, power units, systems and selected high-pressure valves.

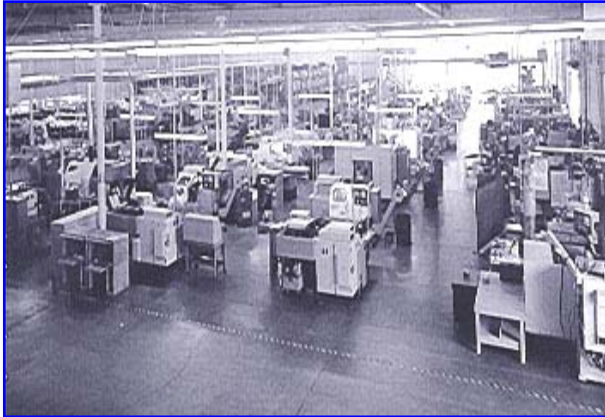

The product line remained stable through the 1980s seeing successful operation in an ever-increasing number of installations and applications, while sales grew through an expansion of distribution.

Under the leadership of Bob Vedder's daughter, Donna Perez, SC Hydraulic operates a state-of-the-art 65,000 square-foot facility in Brea, California, and is well prepared for future growth and innovation.

Where Hydraulic Force Meets Custom Engineering

With products capable of achieving pressures exceeding 70,000 psig, SC Hydraulic Engineering Corp. is a force to be reckoned with in the field of hydraulic engineering.

SC Hydraulic manufactures a vast array of air-operated hydraulic pumps and boosters for a variety of industries. In addition to our current line of hydraulic products, we can work with you to custom design products to fit the exact specifications of your applications.

An international leader in hydraulic engineering, SC Hydraulic is staffed with educated and certified engineers. They are continually developing new products which are in sync with newly emerging applications, both in the United States and abroad.



In a 65,000 square foot facility, SC Hydraulic is capable of setting the industry's highest standard while maintaining the best delivery times

For Fluid Power...

Contact SC Hydraulic today, to find out more about our capabilities or for a technical data sheet.

OLD PART NUMBERS VERSUS NEW MODEL NUMBERS

SC Hydraulic Engineering has changed the model numbering codes for our flow control and air pilot switch valves. The purpose of the change is to ease the ordering and identification of our valves.

To help in the transition the following chart shows old part numbers and the new model coding.

| OLD MODEL | NEW MODEL |
|------------------------------------|---------------|
| INLINE CHECK VALVES | |
| CV250 | ICV-150-N-025 |
| CV375 | ICV-100-T-037 |
| CV500 | ICV-100-T-050 |
| CV1000 | ICV-080-T-100 |
| AIR SEQUENCE VALVE | |
| 70-1008A100 | ASV-100-N-050 |
| PRESSURE RELEASE VALVES | |
| 20-4000A060 | PRC-060-N-100 |
| 20-4001A100 | PRC-100-N-050 |
| 20-4000A200 | PRC-200-N-050 |
| 20-4000A300 | PRC-300-N-HF9 |
| PUV-55 | PRO-050-N-025 |
| PUV-120 | PRO-011-N-025 |
| DIRECT ACTING RELIEF VALVES | |
| 20-5000S010 | DRV-010-N-025 |
| 20-5000S050 | DRV-050-N-025 |
| 20-5000S100 | DRV-100-N-025 |
| 20-5000S200 | DRV-200-N-025 |
| 20-5000S300 | DRV-300-N-HF4 |
| 20-5000S600 | DRV-600-N-HF4 |

| OLD MODEL | NEW MODEL |
|-------------------------|------------------|
| AIR PILOT SWITCH | |
| V10301-1 | APS-100-01-N-025 |
| V10301-2 | APS-070-02-N-025 |
| V10301-3 | APS-051-03-N-025 |
| V10301-4 | APS-013-04-N-025 |
| V10301-5 | APS-148-05-N-025 |
| V10305-1 | APS-100-06-N-025 |
| V10305-2 | APS-070-07-N-025 |
| V10305-3 | APS-050-08-N-025 |
| V10305-4 | APS-012-09-N-025 |
| V10303-1 | APS-005-10-N-025 |
| V10303-2 | APS-002-11-N-025 |
| V10303-3 | APS-001-12-N-025 |
| V10303-4 | APS-000-13-N-025 |
| V10304-1 | APS-005-14-N-025 |
| V10304-2 | APS-002-15-N-025 |
| V10304-3 | APS-001-16-N-025 |
| V10304-4 | APS-000-17-N-025 |

CV SERIES INLINE CHECK VALVES



SC Hydraulic Engineering inline check valves are designed for high shock loads using a ball check for positive sealing. The all stainless steel construction will handle most liquids or gas. Cracking pressure on all sizes is one to three psi.

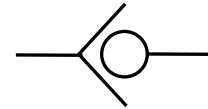
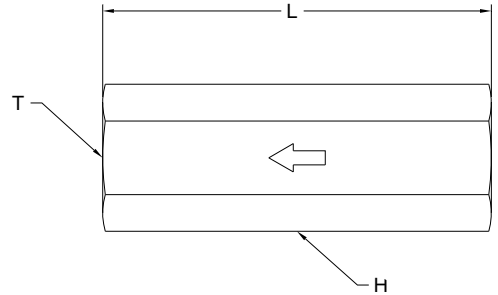

| MODEL NO. | "T" THREAD NPT | "H" DIM. HEX | "L" DIM. | Cv FACTOR | MAX. WORKING PRESSURE (PSI) | MATERIAL |
|---------------|----------------|--------------|----------|-----------|-----------------------------|----------|
| ICV-150-N-025 | 1/4" | 15/16" | 2.37" | 0.40 | 15,000 | 316 SS |
| ICV-100-T-037 | 3/8" | 1 1/8" | 2.88" | 1.10 | 10,000 | 303 SS |
| ICV-100-T-050 | 1/2" | 1 1/8" | 3.44" | 1.95 | 10,000 | 303 SS |
| ICV-080-T-100 | 1" | 1 1/2" | 4.88" | 5.05 | 8,000 | 303 SS |

AIR SEQUENCE VALVE

The **ASV-001-N-050** Air Sequence Valve is a normally closed adjustable pilot operated valve used to divert air pressure to a branch circuit after a set pressure is achieved. The internal pilot setting can be adjusted from 25 to 100 psi and the valve can be mounted in any position.

The 1/2 " NPT ports and poppet design allows ample flow through the valve.

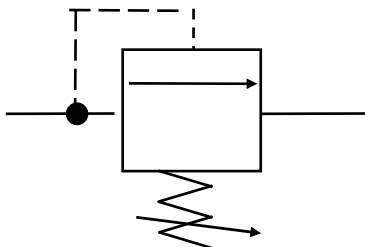
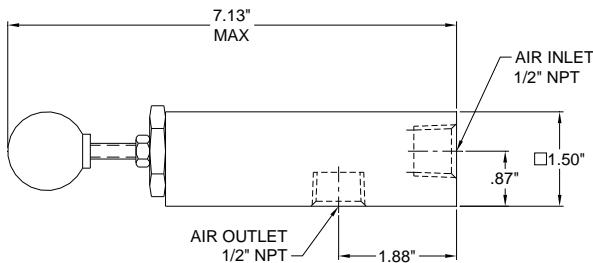

ASV-001-N-050



PRO & PRC PRESSURE RELEASE VALVE



SC Pressure Release Valves are available in normally open and normally closed configurations. All of the valves are air actuated and are compatible with most fluids including water and synthetic compounds. Seals are Buna-N as standard (-N). Substitute “-V” for Viton® seals or “-E” for EPR.



Typically, pressure release valves are used to release pressure on single acting cylinders, hydrostatic test applications, or for providing a safety relief in a circuit.

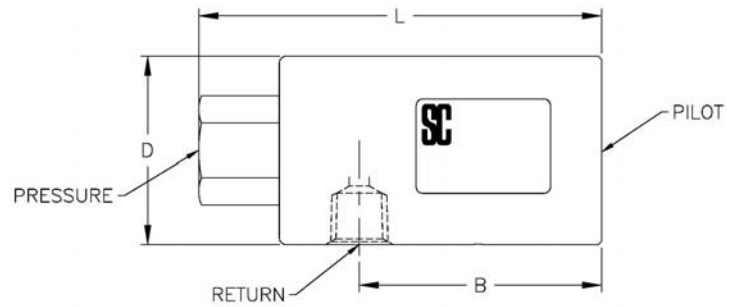
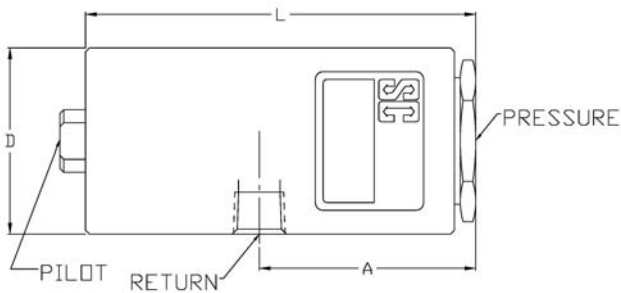
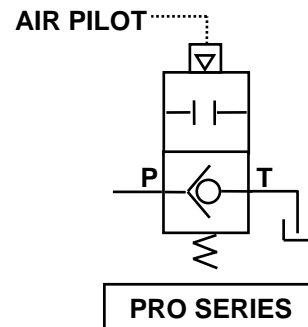
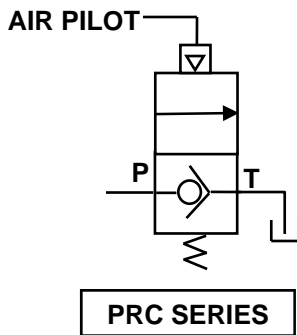

| PILOT OPERATED PRESSURE RELEASE VALVE | | | | | | | | | | | |
|---------------------------------------|------------------|---------------------------|-----------------------|------------------|----------|----------|------------------------------------|----------------------------|---------------|---------------|---------------|
| Model No. | Normal Condition | Pilot Ratio for Actuation | Max Op Pressure (psi) | Connection Ports | | | Cracking Press. Reverse Flow (psi) | Pilot Press. at Max. (psi) | "L" Dim. Inch | "A" Dim. Inch | "D" Dim. Inch |
| | | | | Pressure | Return | Pilot | | | | | |
| PRC-060-N-100 | Closed | 120:1 | 6,000 | 1" NPT | 1" NPT | 1/4" NPT | 20 | 50 | 7.90 | 4.56 | 2.75 |
| PRC-100-N-050 | Closed | 285:1 | 10,000 | 1/2" NPT | 1/2" NPT | 1/4" NPT | 5 | 35 | 6.73 | 3.50 | 3.00 |
| PRC-200-N-050 | Closed | 500:1 | 20,000 | 1/2" NPT | 1/2" NPT | 1/4" NPT | 10 | 40 | 6.73 | 3.50 | 3.00 |
| PRC-300-N-HF9 | Closed | 850:1 | 30,000 | 1-1/8-12 HF9* | 3/8" NPT | 1/4" NPT | 5 | 35 | 6.54 | 3.94 | 3.00 |
| PRO-050-N-025 | Open | 55:1 | 5,000 | 1/4" NPT | 1/4" NPT | 1/4" NPT | N/A | 90 | 3.75 | 1.50 | 1.75 |
| PRO-011-N-025 | Open | 120:1 | 11,000 | 1/4" NPT | 1/4" NPT | 1/4" NPT | N/A | 90 | 3.75 | 1.50 | 1.75 |

* for 9/16 O.D. coned & threaded 40,000 psi tubing

DRV DIRECT ACTING RELIEF VALVE

SC Hydraulic Engineering direct acting relief valves are available in 1/4" NPT and 9/16-18 60° cone high pressure fitting for relieving pressures from 100 to 60,000 psi. The stainless steel construction makes these valves suitable for hydraulic fluids, water and gas applications. Standard seal material is Buna-N (-N). Substitute a "-V" for Viton® or "-E" for EPR after the part number for these seals. Specify "-V" seals for gas applications.

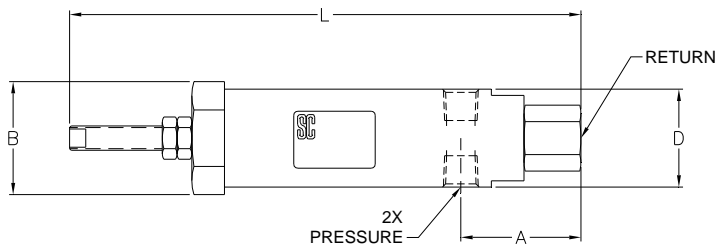

TYPE A

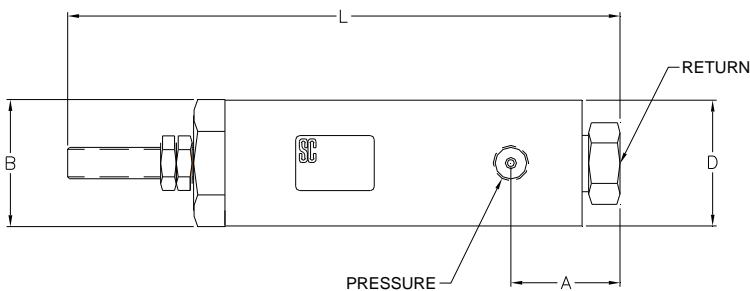

TYPE B

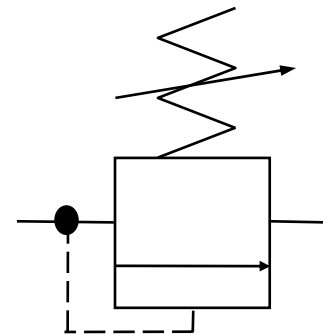

DIRECT ACTING RELIEF VALVE

| Model No. | Type | Adjustment Range | Connection Ports | | Service | "L" Dim. Inch | "A" Dim. Inch | "B" Dim. Inch | "D" Dim. Inch |
|---------------|------|-----------------------|------------------|--------------|------------------|---------------|---------------|---------------|---------------|
| | | | Inlet | Tank | | | | | |
| DRV-010-N-025 | A | 100 to 1,000 psig | 2ea 1/4" NPT | 1/4" NPT | Gas ** Liquid | 7.31 Max | 1.84 | 1.73 | 1.50 Ø |
| DRV-050-N-025 | A | 500 to 5,000 psig | 2ea 1/4" NPT | 1/4" NPT | Gas ** Liquid | 7.31 Max | 1.84 | 1.73 | 1.50 Ø |
| DRV-100-N-025 | A | 1,000 to 10,000 psig | 2ea 1/4" NPT | 1/4" NPT | Gas ** Liquid | 7.85 Max | 1.84 | 1.73 | 1.50 Ø |
| DRV-200-N-HF4 | B | 5,000 to 20,000 psig | 9/16-18 HF4* | 9/16-18 HF4* | Gas ** Liquid | 8.79 Max | 1.76 | 2.02 | 2.00 Ø |
| DRV-300-N-HF4 | B | 10,000 to 30,000 psig | 9/16-18 HF4* | 9/16-18 HF4* | Liquid | 8.79 Max | 1.76 | 2.02 | 2.00 Ø |
| DRV-600-N-HF4 | B | 10,000 to 60,000 psig | 9/16-18 HF4* | 9/16-18 HF4* | Liquid | 8.79 Max | 1.76 | 2.02 | 2.00 Ø |

* for 1/4 O.D. coned & threaded 30K & 60K psi tubing

** Use Viton seals for gas applications

APS AIR PILOT SWITCH VALVE

The APS Air Pilot Switch consists of a high pressure sensor operator connected directly to a three-way air valve that can be operated either normally open (passing air) or closed (not passing air). The spring in the sensor applies a counteracting force to the switch and is adjustable within the spring range.



All air pilot switches are subject to deadband conditions, which should be considered when using the valve. A deadband is described as the difference in pressure between a set point of sensing pressure and a pressure at which the air valve returns to the original position. Deadband conditions vary by pressure range in percentage with higher pressure conditions reducing the deadband range.

SC will preset the APS to a specified pressure if requested. Indicate if the switch is to activate under increasing or decreasing pressure condition. Consult SC for more information if needed.

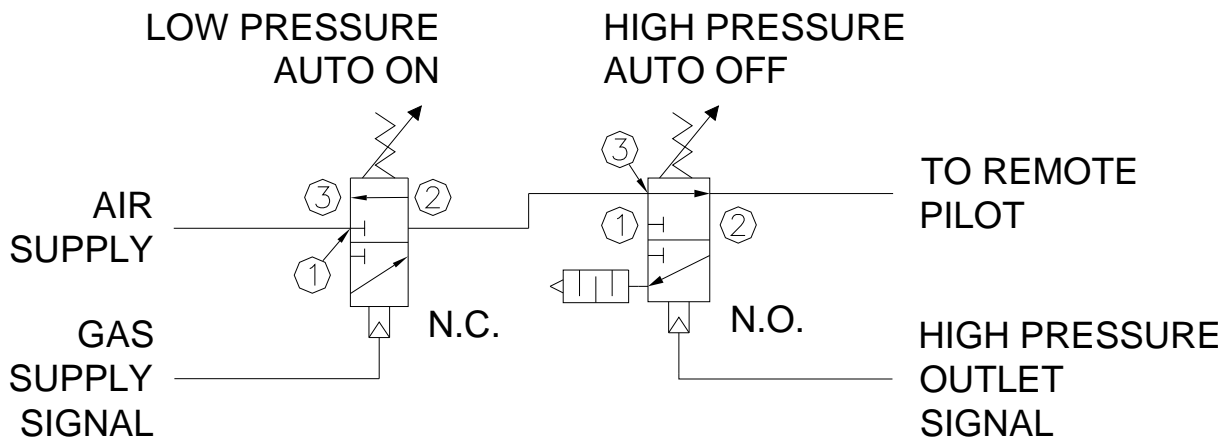

TYPICAL AUTO ON/OFF SETUP

APS AIR PILOT SWITCH VALVE

TYPE A

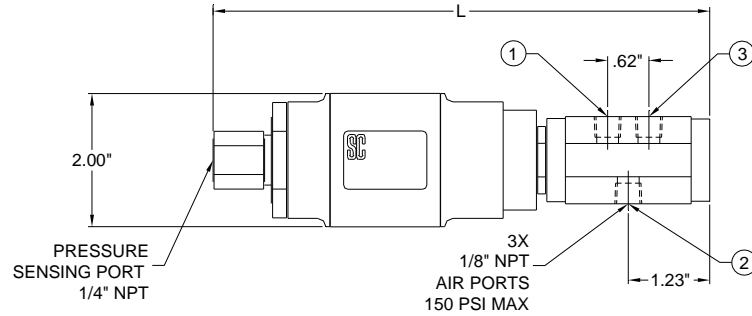

TYPE B

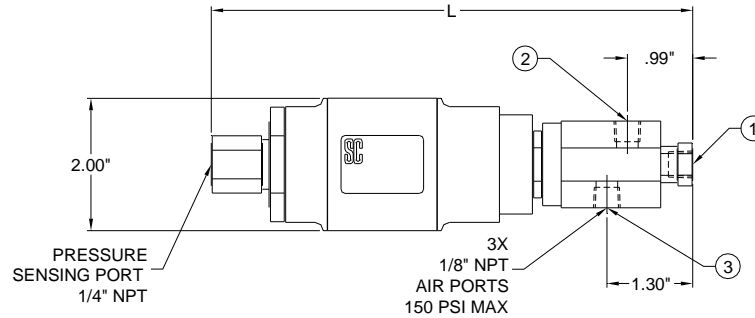

AIR PILOT SWITCH VALVE SELECTION

| Model No.* | Type | System Order Code | Sensing Port | | Adjustable Range (psig) Pressure setting at factory. Specify increasing/decreasing | | Air Valves 150 psig Maximum Operating Pressure | | Air Valve Configure Option |
|------------|------|-------------------|--------------|--------------------------------------|--|---------------|--|-------------------------|----------------------------|
| | | | Size | Max. Pressure | Normally Closed | Normally Open | Port Size | Cv Factor | |
| | | | | | | | | | |
| APS-100-01 | A | 01 | 1/4" NPT | 15,000 psi O ₂ = 5,000 | 3,500-10,000 | 2,400-10,000 | 1/8" npt | .20 UP TO 11 SCFM | N.C. & N.O. |
| APS-070-02 | | 02 | | | 1,400-7,000 | 940-6,400 | | | |
| APS-051-03 | | 03 | | | 800-5,100 | 700-4,600 | | | |
| APS-013-04 | | 04 | | | 340-1,300 | 260-1,200 | | | |
| APS-148-05 | | 05 | | | 3,500-14,800 | 2,500-12,000 | | | |
| APS-100-06 | B | 06 | 1/4" NPT | 15,000 psi O ₂ = 5,000 | 3,500-10,000 | | 1/8" npt | .13 UP TO 7 SCFM | N.C. |
| APS-070-07 | | 07 | | | 1,360-7,000 | | | | |
| APS-050-08 | | 08 | | | 680-5,000 | | | | |
| APS-012-09 | | 09 | | | 230-1,240 | | | | |
| APS-005-10 | A | 10 | 1/4" NPT | 3,000 psi | 170-550 | 125-510 | 1/8" npt | .20 UP TO 11 SCFM | N.O. & N.C. |
| APS-002-11 | | 11 | | | 70-210 | 50-190 | | | |
| APS-001-12 | | 12 | | | 50-130 | 40-130 | | | |
| APS-000-13 | | 13 | | | 25-50 | 20-46 | | | |
| APS-005-14 | B | 14 | 1/4" NPT | 3,000 psi | 145-520 | | 1/8" npt | .13 UP TO 7 SCFM | N.C. |
| APS-002-15 | | 15 | | | 55-210 | | | | |
| APS-001-16 | | 16 | | | 30-135 | | | | |
| APS-000-17 | | 17 | | | 15-45 | | | | |
| APS-200-18 | A | 18 | HF4 | 20,000 psi | 3,000-20,000 | 3,000-20,000 | | .20 UP TO 11 SCFM | N.O. & N.C. |

* Refer to "How to Order" page for complete model number callout.

HOW TO ORDER TABLE



1 2 3 4 Table Reference

Example #1 **ASV - 001 - N - 050**

Air Sequence Valve

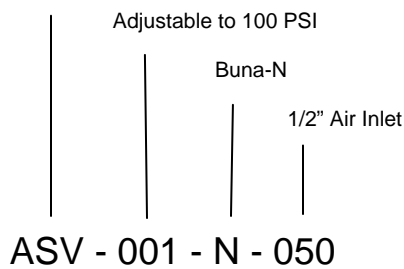

Example #2 **APS - 148-05 - N - 025**

Air Pilot Switch Valve

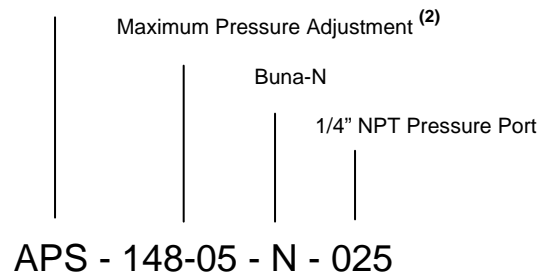

TABLE 1 ⁽¹⁾ **Valve Series**

| | |
|------------|----------------------------------|
| ICV | Inline Check Valve |
| ASV | Air Sequence Valve |
| PRC | Pressure Release Normally Closed |
| PRO | Pressure Release Normally Open |
| DRV | Direct Acting Relief Valve |
| APS | Air Pilot Switch Valve |

TABLE 3 ⁽³⁾ **Seal Compound**

| | |
|----------|--------|
| N | Buna-N |
| V | Viton™ |
| E | EPR |
| T | PTFE |

TABLE 2 **Max Operating Pressure**

Examples

| | |
|------------|-------------------|
| 000 | Less than 100 PSI |
| 001 | 100 PSI |
| 010 | 1,000 PSI |
| 011 | 1,100 PSI |
| 100 | 10,000 PSI |
| 110 | 11,000 PSI |

TABLE 4 ⁽³⁾ **Pressure Port Size**

| | |
|------------|--------------------------|
| 025 | 1/4" NPT |
| 037 | 3/8" NPT |
| 050 | 1/2" NPT |
| 100 | 1" NPT |
| HF4 | High Pressure for 60 KSI |
| HF9 | High Pressure for 40 KSI |

Add Code Number on APS Valve Only ⁽²⁾

Notes:

1. Refer to Conversion Page for Prior Model Number Callouts
2. Add Code Number on APS Valve
3. Not all options are available on all valves

LIMITED WARRANTY

SC manufactured products are warranted free of original defects in material and workmanship for a period of one year from date of purchase to first user. This warranty does not include packing, seals or failures caused by lack of proper maintenance, incompatible fluids, foreign materials in the air media, in the fluid media or application of pressures beyond catalog ratings. Products believed to be originally defective may be returned, freight prepaid, for repair and/or replacement to the distributor, authorized service representative or to the factory. If upon inspection by the factory or authorized service representative and the problem is found to be originally defective material or workmanship, repair or replacement will be made at no charge for labor and materials, F.O.B. the point of repair or replacement. Permission to return under warranty should be requested prior to shipment. A Return Material Authorization Number (RMA), the original purchase date, purchase order number, serial number, model number, reason for return or other pertinent data to establish warranty claim must be included in the documentation to expedite the return or replacement to the owner.

If the unit has been disassembled, misused, or altered without prior **written** authorization, warranty is void. If it has been improperly reassembled or substitute parts have been used in place of factory manufactured parts, warranty is void.

Any modification to any SC product which you have made or may make in the future will void warranty. SC disclaims any and all liability obligation, or responsibility for the modified product, and for any claims, demands or causes of action for damage or for personal injuries resulting from the modification and/or use of such a modified SC product.

SC's obligation with respect to its products shall be limited to replacement, and in no event shall SC be liable for any loss or damage, consequential or special, of whatever kind or nature, or any other expense which may arise in connection with or as a result of such products or the use or incorporation thereof in a job. This warranty is expressly made in lieu of all other warranties of merchantability and fitness for a particular purpose. No express warranty and no implied warranties whether of merchantability or fitness for a particular purpose or otherwise, other than those expressly set forth above, shall apply to SC products.

Distributed by:



Designers and Manufacturers of Hydraulic and Pneumatic Equipment

SC HYDRAULIC ENGINEERING CORPORATION

1130 Columbia Street - Brea, California 92821 - USA Phone: (714) 257-4800 - Fax: (714) 257-4810