



Designer and Manufacturer of Hydraulic and Pneumatic Equipment

SC HYDRAULIC ENGINEERING CORPORATION

1130 Columbia Street - Brea, California 92821 - USA • Phone (714) 257-4800 - Fax (714) 257-4810

**L6 & L7 SERIES
AIR OPERATED
LIQUID PUMP**

P
U
M
P
S

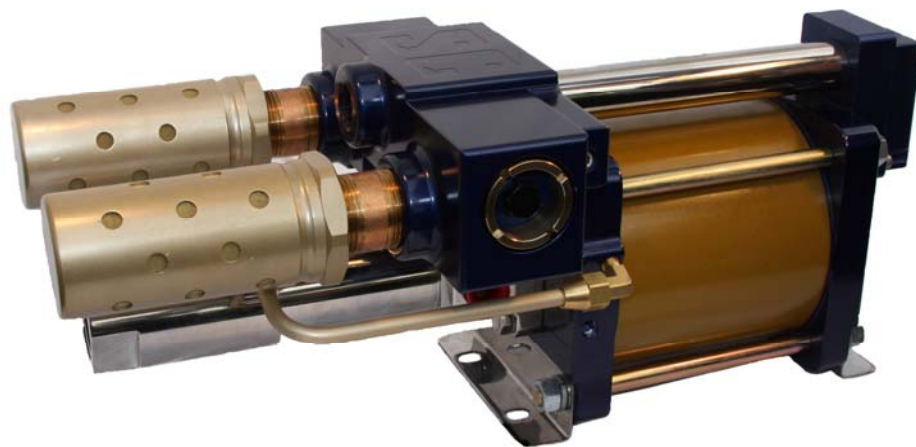

A "High Pressure" History...

An innovator and pioneer in the field of hydraulic engineering, SC Hydraulic has been manufacturing air-driven liquid pumps for more than a half of a century.

Founded in 1953 by Bob Vedder and Willie Mohler, the company started with only a few core products. Basically air-driven liquid pumps. Today, SC Hydraulic's product line has expanded to include an extensive collection of air and gas boosters, power units, systems and selected high-pressure valves.

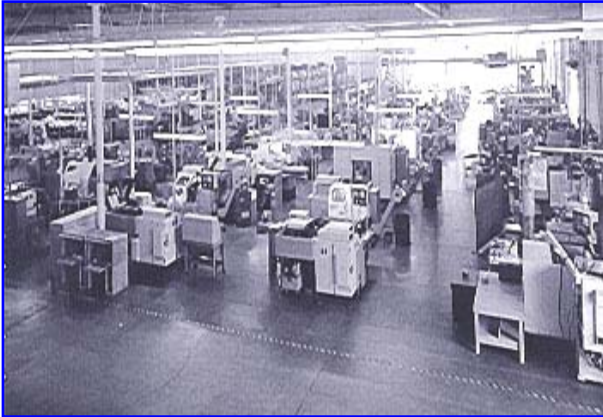

The product line remained stable through the 1980s seeing successful operation in an ever-increasing number of installations and applications, while sales grew through an expansion of distribution.

Under the leadership of Bob Vedder's daughter, Donna Perez, SC Hydraulic operates a state-of-the-art 65,000 square-foot facility in Brea, California, and is well prepared for future growth and innovation.

Where Hydraulic Force Meets Custom Engineering

With products capable of achieving pressures exceeding 70,000 psig, SC Hydraulic Engineering Corp. is a force to be reckoned with in the field of hydraulic engineering.

SC Hydraulic manufactures a vast array of air-operated hydraulic pumps and boosters for a variety of industries. In addition to our current line of hydraulic products, we can work with you to custom design products to fit the exact specifications of your applications.

An international leader in hydraulic engineering, SC Hydraulic is staffed with educated and certified engineers. They are continually developing new products which are in sync with newly emerging applications, both in the United States and abroad.



In a 65,000 square foot facility, SC Hydraulic is capable of setting the industry's highest standard while maintaining the best delivery times

For Fluid Power...

Contact SC Hydraulic today, to find out more about our capabilities or for a technical data sheet.

L6 SERIES

High Flow Liquid Pump

The SC L6 Series pump has a 6" diameter drive section and stainless steel wetted parts in the hydraulic section. This double acting high flow pump is capable of hydraulic pressures up to 11,200-psi and is available in three pressure ratios: 40:1, 60:1 and 100:1.

It is designed to operate with air drive pressures between 15-psi and 100-psi. Air consumption under normal operating conditions ranges from 50-SCFM to 160-SCFM depending on outlet pressure required. It is dimensionally interchangeable with competitive model pumps.

Typical applications include choke control operation, hydrostatic testing and press applications.

APPLICATIONS

- **Sub-sea valve actuation.**
- **Safety shut down valves.**
- **Wireline control systems.**
- **Blowout preventer control systems.**
- **Bolt tensioning.**
- **Pressure testing.**

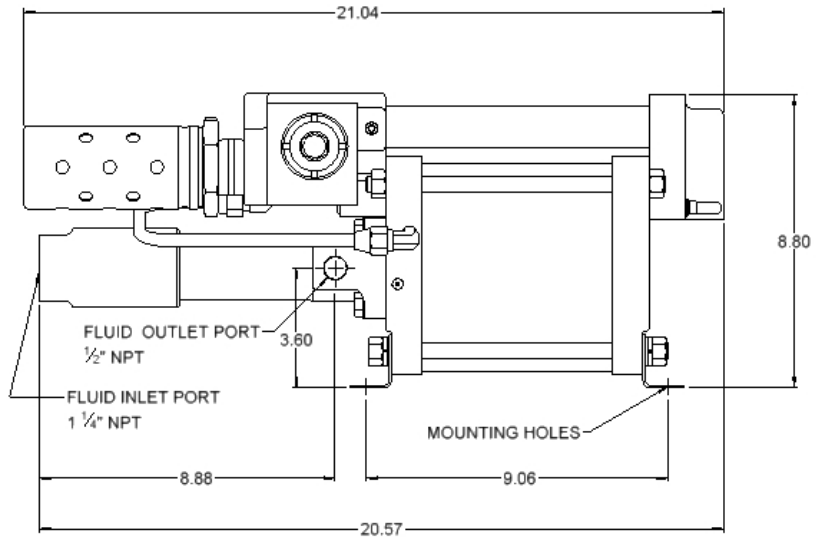
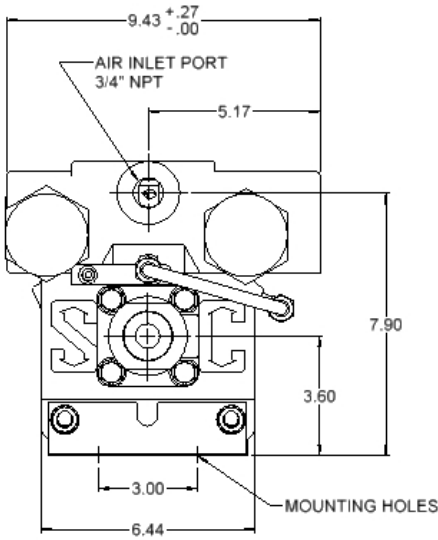

Mounting Dimensions in Inches

Dash Number	Actual Ratio	Max. Outlet Pressure (100 psig Air Supply)	Displacement Per Cycle Cu. In.	Connection Ports NPT	
				A Inlet	B Outlet
-40	40.3	3,950	6.0	1 1/4"	1/2"
-60	69.0	6,420	3.5	1 1/4"	1/2"
-100	115.0	11,200	2.1	1 1/4"	1/2"

L6 SERIES

High Flow Liquid Pump

L6-40

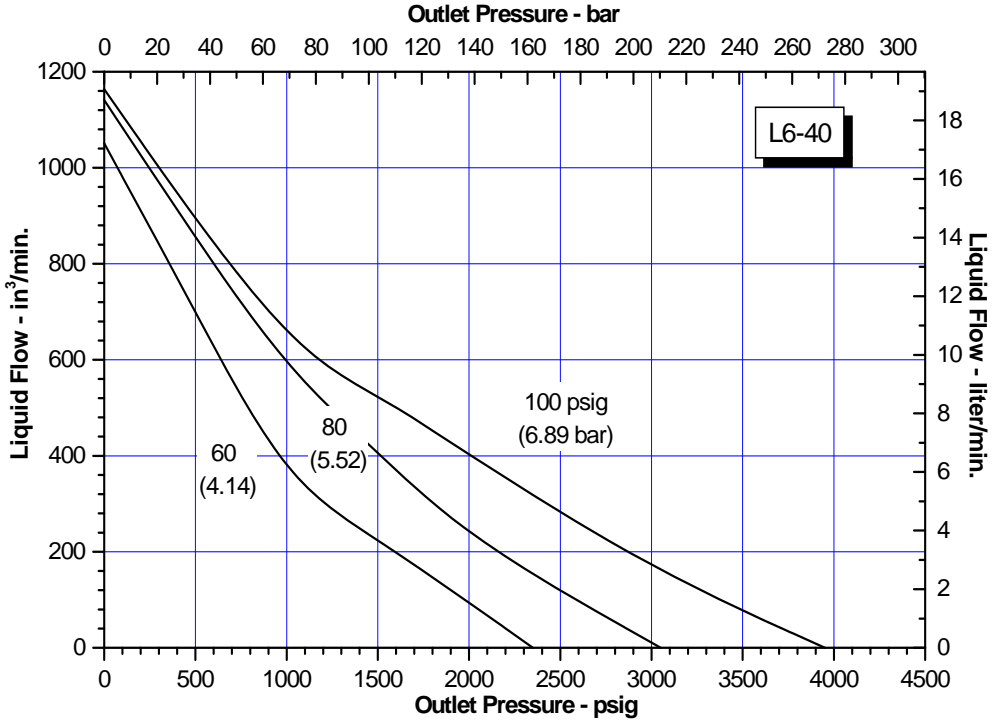

L6-60

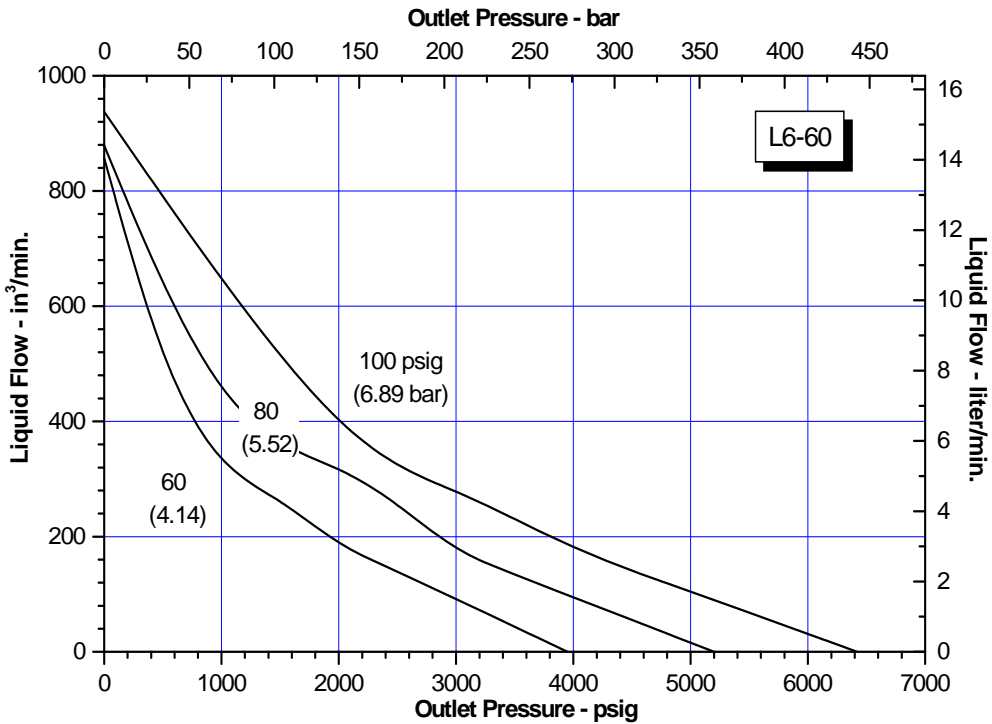

L6 SERIES

High Flow Liquid Pump

L6-100

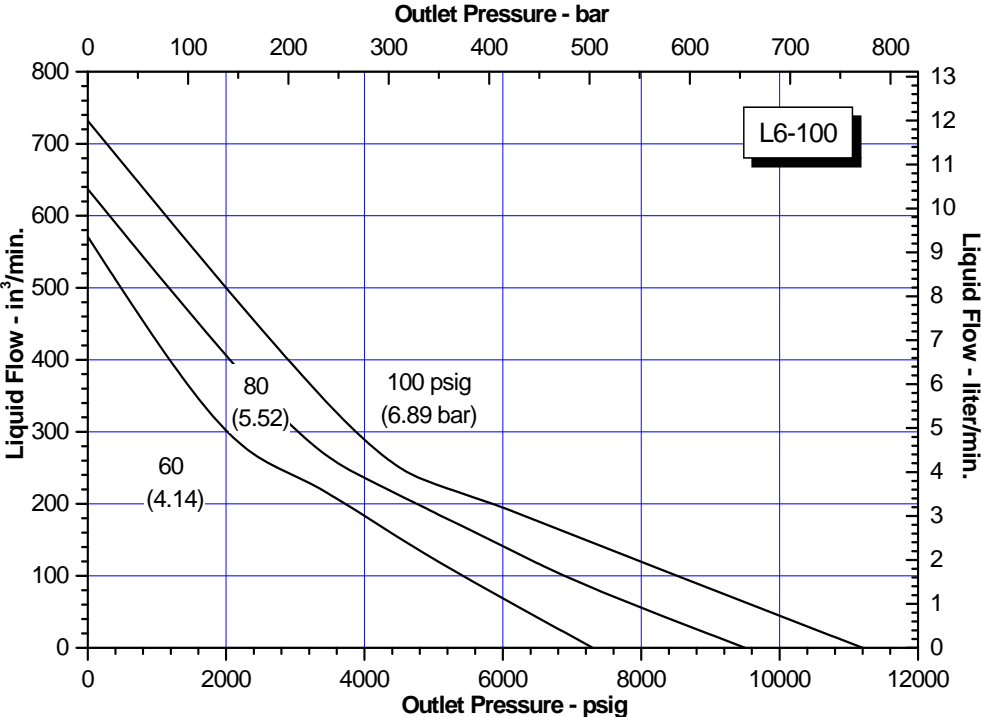

L7 SERIES

High Flow Liquid Pump

The SC L7 Series pump has a 7" diameter drive section and stainless steel wetted parts in the hydraulic section. This double air motor and double acting high flow pump is capable of hydraulic pressures up to 12,800-psi.

It is designed to operate with air drive pressures between 15-psi and 100-psi. Air consumption under normal operating conditions ranges from 150-SCFM to 210-SCFM depending on outlet pressure required.

Typical applications include choke control operation, hydrostatic testing and press applications.

APPLICATIONS

- **Sub-sea valve actuation.**
- **Safety shut down valves.**
- **Wireline control systems.**
- **Blowout preventer control systems.**
- **Bolt tensioning.**
- **Pressure testing.**

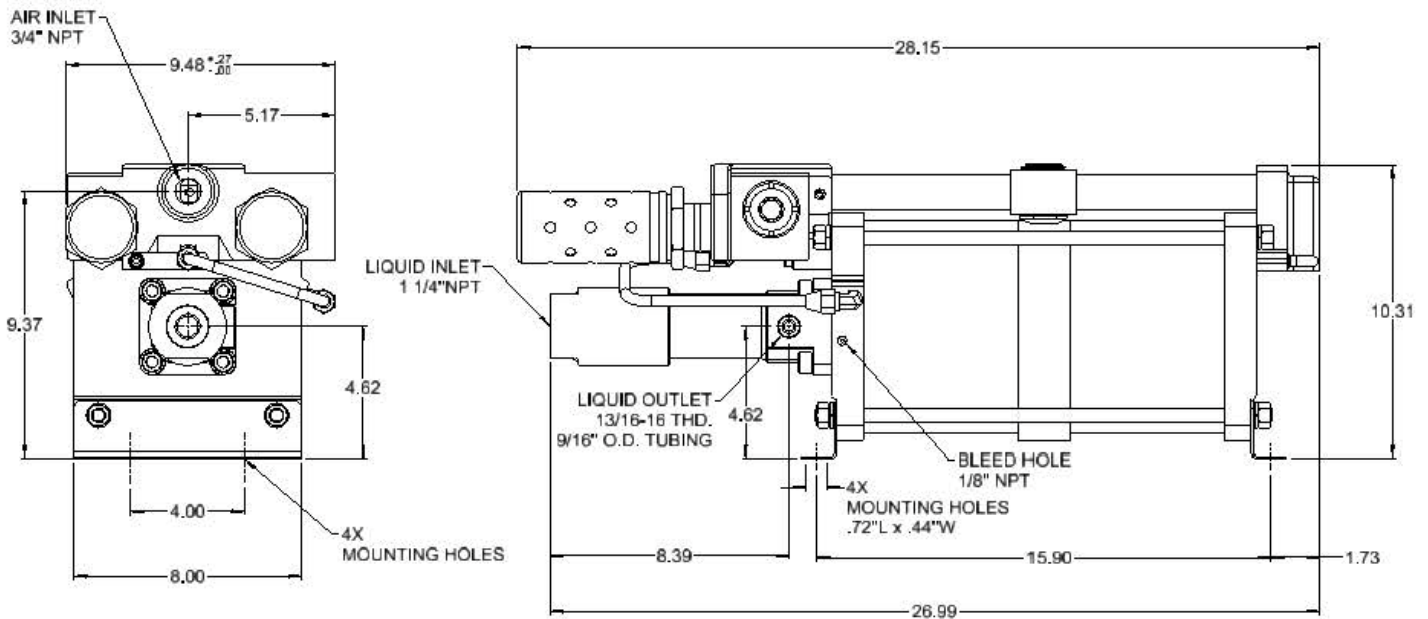

Mounting Dimensions in Inches

Dash Number	Actual Area Ratio	Max. Outlet Pressure (100 psig Air Supply)	Displacement Per Cycle Cu. In.	Connection Ports	
				Inlet	Outlet
-120	134:1	12,800	4.7	1 1/4" NPT	13/16-16*

* Coned and Threaded Connection for 9/16" OD Tube

L7 SERIES

High Flow Liquid Pump

L7-120

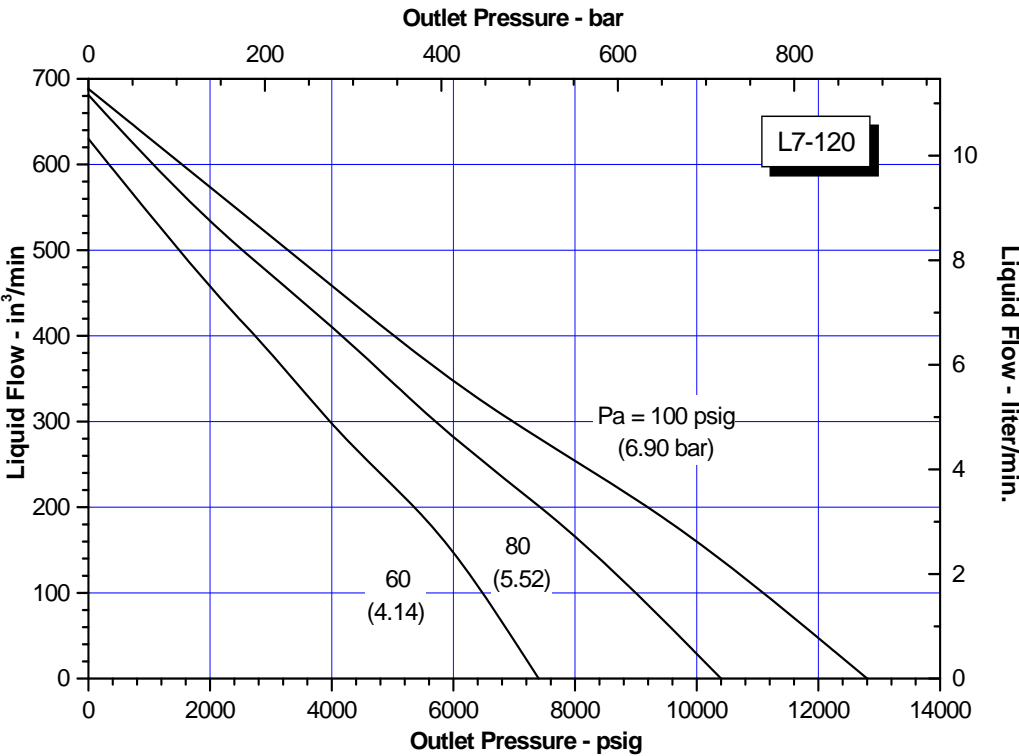

HOW TO ORDER TABLE

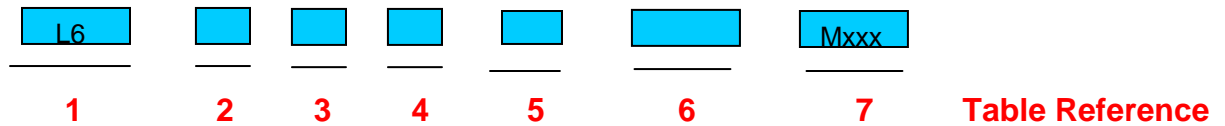

Example #1 showing no modification

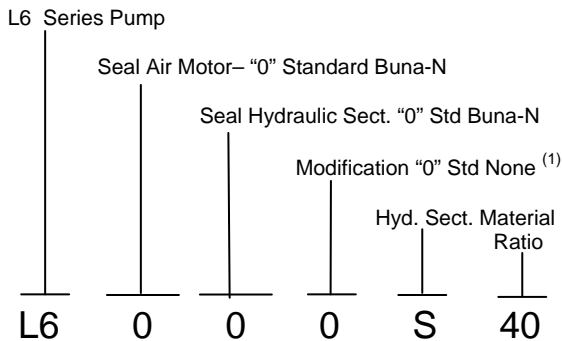

Example #2 showing modifications:

Viton Seals in air motor, Viton seals in hydraulic section, counter port and remote pilot.

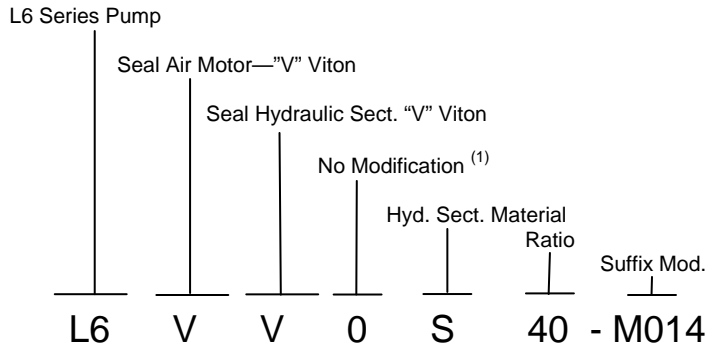

TABLE 1 Pump Series Designation

L6	6" Bore Drive Air Motor Pump
L7	7" Bore Drive Air Motor Pump

TABLE 2 Air Motor Seals

0	Buna-N
V	Viton®

TABLE 3 L6 Hydraulic Section Seals

0	Buna-N/Polyurethane
V	Viton®
E	EPR (Ethylene Propylene)

TABLE 3 L7 Hydraulic Section Seals

0	UHMWPE/Buna-N
V	UHMWPE/Viton®
E	UHMWPE/EPR (Ethylene Propylene)

TABLE 4 Modifications

0	No Modification
----------	-----------------

TABLE 5 Material of Construction—Hydraulic Section

S	Stainless Steel
----------	-----------------

TABLE 6 L6 Actual Area Ratio

40	40.3:1 Actual Area Ratio
60	69:1 Actual Area Ratio
100	115:1 Actual Area Ratio

TABLE 6 L7 Actual Area Ratio

120	134:1 Actual Area Ratio
------------	-------------------------

TABLE 7 Suffix Modifications

Blank	No Modification (Remote Pilot Included) ⁽¹⁾
M014	Counter Port, 5/8-18 UNF-2B Thd.

Additional Modifications may be included with an "M" suffix at the end of the model number.

Notes:

(1) Remote Pilot Modification is built-in on every L6 & L7 Series pump. No modification number is needed when ordering. See L6 & L7 Series Pump Parts Break Down for details.

LIMITED WARRANTY

SC manufactured products are warranted free of original defects in material and workmanship for a period of one year from date of purchase to first user. This warranty does not include packing, seals or failures caused by lack of proper maintenance, incompatible fluids, foreign materials in the air media, in the fluid media or application of pressures beyond catalog ratings. Products believed to be originally defective may be returned, freight prepaid, for repair and/or replacement to the distributor, authorized service representative or to the factory. If upon inspection by the factory or authorized service representative and the problem is found to be originally defective material or workmanship, repair or replacement will be made at no charge for labor and materials, F.O.B. the point of repair or replacement. Permission to return under warranty should be requested prior to shipment. A Return Material Authorization Number (RMA), the original purchase date, purchase order number, serial number, model number, reason for return or other pertinent data to establish warranty claim must be included in the documentation to expedite the return or replacement to the owner.

If the unit has been disassembled, misused, or altered without prior **written** authorization, warranty is void. If it has been improperly reassembled or substitute parts have been used in place of factory manufactured parts, warranty is void.

Any modification to any SC product which you have made or may make in the future will void warranty. SC disclaims any and all liability obligation, or responsibility for the modified product, and for any claims, demands or causes of action for damage or for personal injuries resulting from the modification and/or use of such a modified SC product.

SC's obligation with respect to its products shall be limited to replacement, and in no event shall SC be liable for any loss or damage, consequential or special, of whatever kind or nature, or any other expense which may arise in connection with or as a result of such products or the use or incorporation thereof in a job. This warranty is expressly made in lieu of all other warranties of merchantability and fitness for a particular purpose. No express warranty and no implied warranties whether of merchantability or fitness for a particular purpose or otherwise, other than those expressly set forth above, shall apply to SC products.

Other catalogs available from SC Hydraulic Engineering. Contact your local distributor or us direct and request the one(s) you need by name or number. Catalogs are also available online at www.schydraulic.com.

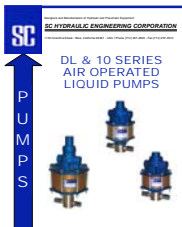

Catalog # D15000

D/10 SERIES AIR OPERATED LIQUID PUMPS

Three sizes to choose from with various ratios. Pressures to 65,000 psi

Catalog # D15001

L3 Series Air Operated Liquid Pumps

Compact sized pumps for pressures up to 15,600 psi plus three styles of power units.

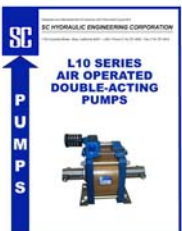

Catalog # D15002

L10 SERIES AIR OPERATED LIQUID PUMPS

10" Air drive double-acting pump for pressures up to 30,000-psi

Catalog # D15004

AIR BOOSTERS & SYSTEMS

Compact and double-acting up to 5:1 ratio plus booster systems with reservoirs and air controls.



Catalog # D15005

AIR OPERATED GAS BOOSTERS

Single and double-acting and two stage boosters up to 25,000 psi plus complete gas booster systems.

Catalog # D15007

D/10 SERIES POWER UNITS

Six different types with and without reservoirs and pressures up to 65,000 psi. All non-electric.



Catalog # D15006

FLOW CONTROL & AIR PILOT SWITCH VALVES

High pressure check, sequence, release, relief, and air pilot switch valves for liquid and gas applications.

Distributed by: